

## 6-Channel Constant Current White LED Driver

### General Description

The LP3361 is a low-dropout bias supply for white LEDs is a high-performance alternative to the simple ballast resistors used in conventional white LED designs. It supports 6 white LEDs with regulated constant current for uniform intensity. The LP3361 maintains low dropout current regulators. The LP3361 requires a 45mV dropout at a 20mA load on each output to match the LED brightness. The brightness of LEDs can be tuned through a pulse width modulated signal at the PWM pin, the PWM frequency from 200Hz to 10KHz and the Duty from 0 to 100%.

The LP3361 is available in a TDFN-10 package.

### Features

- ✧ 2.7V to 6V Input Voltage
- ✧ 20mA maxim sink current
- ✧ Dual Panel Driver of WLED
- ✧ PWM tuned LED brightness through EN pin
- ✧ Soft Start Function
- ✧ Built-in Thermal Protection
- ✧  $I_Q < 1\mu A$  in Shutdown
- ✧ TDFN-10 Package
- ✧ RoHS Compliant and 100% Lead (Pb)-Free

### Typical Application Circuit

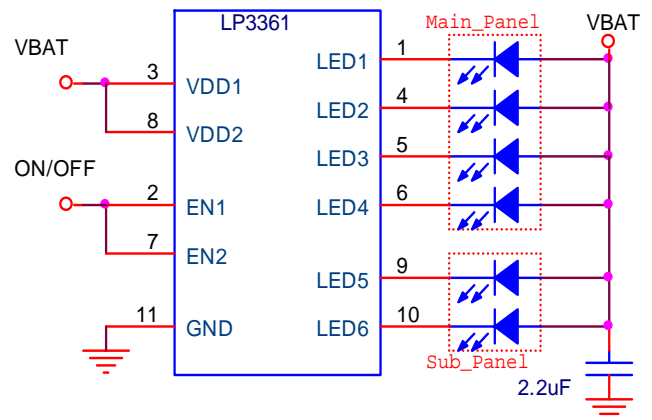

### Order Information

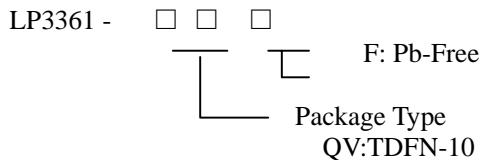

### Applications

- ✧ LCD Panel
- ✧ Cellular and Smart mobile phone
- ✧ PDA/DSC
- ✧ PMP

### Marking Information

Please see website.

### Application Information

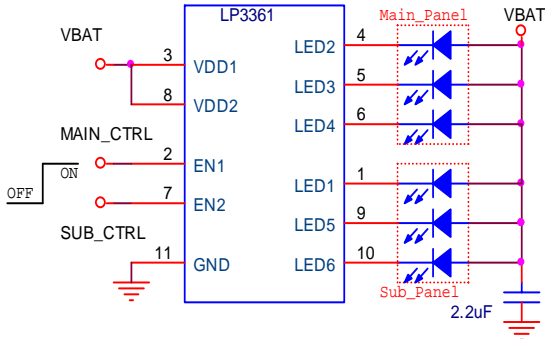

LP3361 Driver Dual Panel Application

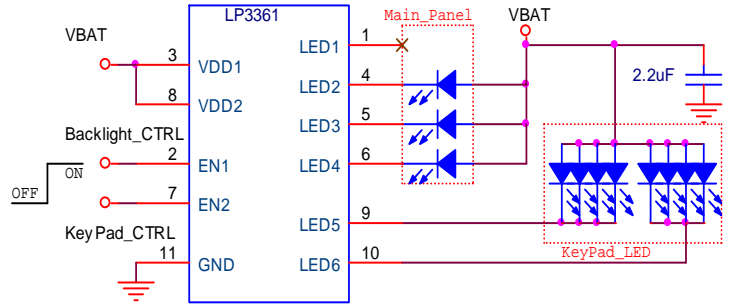

LP3361 Driver Panel and Keypad WLED Application

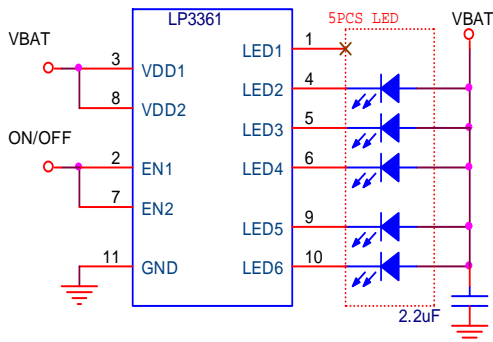

LP3361 Driver 5pcs White-LED Application

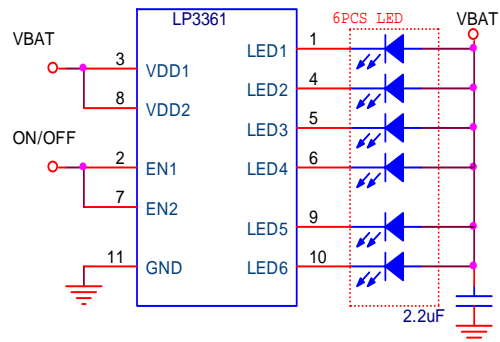

LP3361 Driver 6pcs White-LED Application

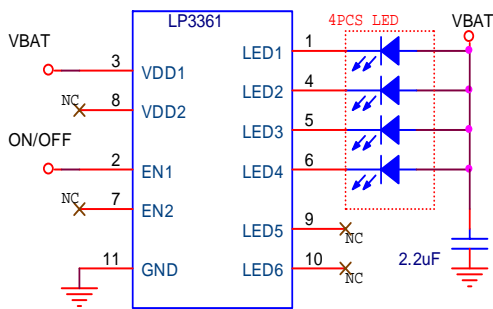

LP3361 Driver 4pcs White-LED Application

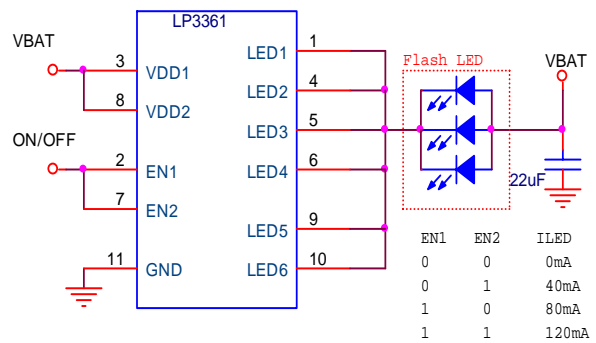

LP3361 Driver Flash White-LED Application

### Functional Pin Description

PIN	NAME	DESCRIPTION
	Package Type	Pin Configurations
	TDFN-10	
1	LED1	LED1 cathode terminal. 20mA Current flows into LED. Floating is used to disable.
2	EN1	Device enable1 (active high).Control from LED2 to LED4 and used a PWM dimming brightness.
3	VDD1	LED1~LED4 power supply.
4	LED2	LED2 cathode terminal. 20mA Current flows into LED. Floating is used to disable.
5	LED3	LED3 cathode terminal. 20mA Current flows into LED. Floating is used to disable.
6	LED4	LED4 cathode terminal. 20mA Current flows into LED. Floating is used to disable.
7	EN2	Device enable2 (active high).Control from LED1,LED5 to LED6 and used a PWM dimming brightness.
8	VDD2	LED5,LED6 power supply.
9	LED5	LED2 cathode terminal. 20mA Current flows into LED. Floating is used to disable.
10	LED6	LED2 cathode terminal. 20mA Current flows into LED. Floating is used to disable.
11	GND	GND.

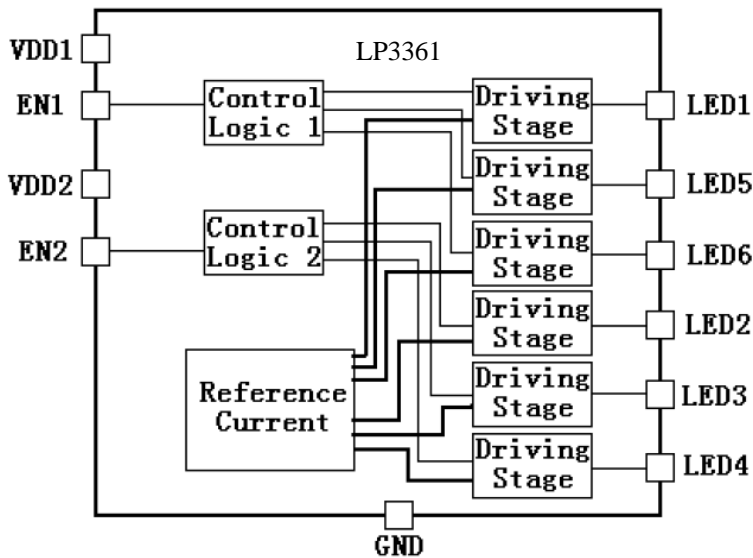

## Absolute Maximum Ratings

- ✧ Input Voltage to GND (VDD1, VDD2) -----6.5V
- ✧ EN to GND Voltage (V<sub>EN</sub>) ----- -0.3V to V<sub>in</sub>+0.3V
- ✧ Operating Junction Temperature Range (T<sub>J</sub>) ----- -40°C to 125°C
- ✧ Maximum Soldering Temperature (at leads, 1 0sec) -----300°C

### Thermal Information

- ✧ Maximum Power Dissipation (P<sub>D</sub>) DFN-10----- 1.5W
- ✧ Thermal Resistance (J<sub>A</sub>) -----58°C/W

## Electrical Characteristics

(Over recommended operating conditions unless specified otherwise) V<sub>INA</sub> =3.6V,EN=High, T<sub>A</sub>=25°C )

Symbol	Parameter	Conditions	LP3361			Unit
			Min.	Typ.	Max.	
V <sub>IN</sub>	Input Voltage		3		5.5	V
I <sub>Q</sub>	Quiescent Current	No Load,		75	75	uA
I <sub>SHDN</sub>	Shutdown Current	EN = GND		0.1	1	μA
I <sub>LED-ERR</sub>	LED Current Accuracy	3mA< I <sub>LED</sub> <30mA	19.4	20	20.6	mA
I <sub>LED-LED-ERR</sub>	LED Channel Matching	Any two channel mismatch	-3		3	%
V <sub>EN(L)</sub>	Enable Threshold Low				0.5	V
V <sub>EN(H)</sub>	Enable Threshold High		2			V

### Typical Operating Characteristics

LED Current vs. Input Voltage

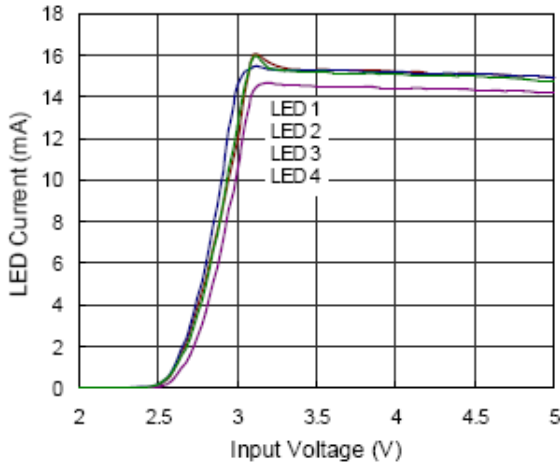

Output Current vs.  $V_{EN}$

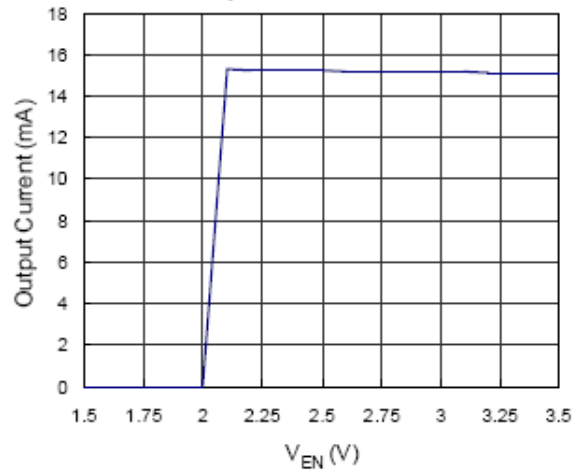

LED Current vs. Temperature

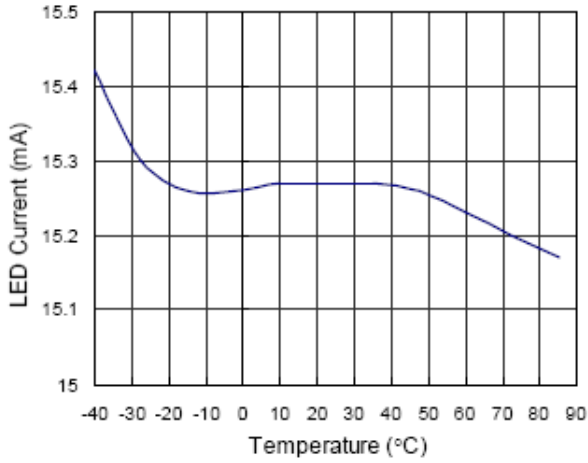

$I_{EN}$  Current vs.  $V_{EN}$  Supply Voltage

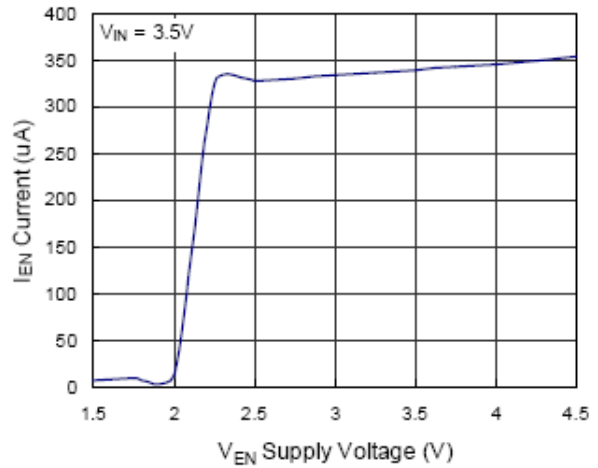

Dimming Operation

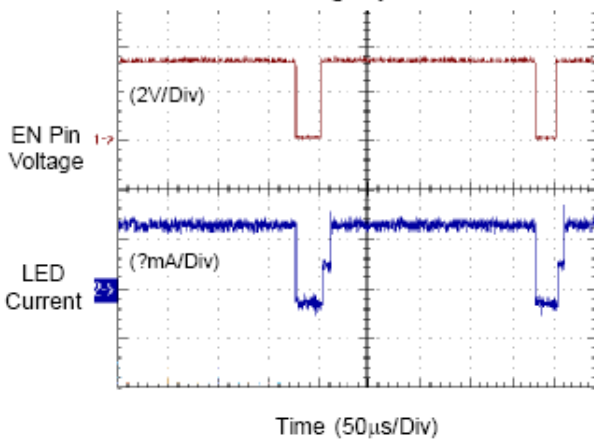

EN Pin Shutdown Response

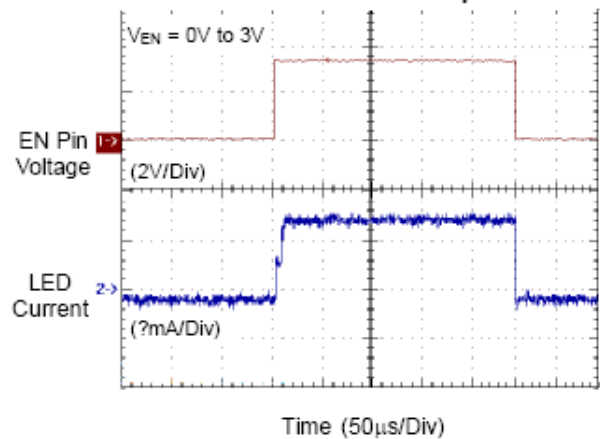

Packaging Information

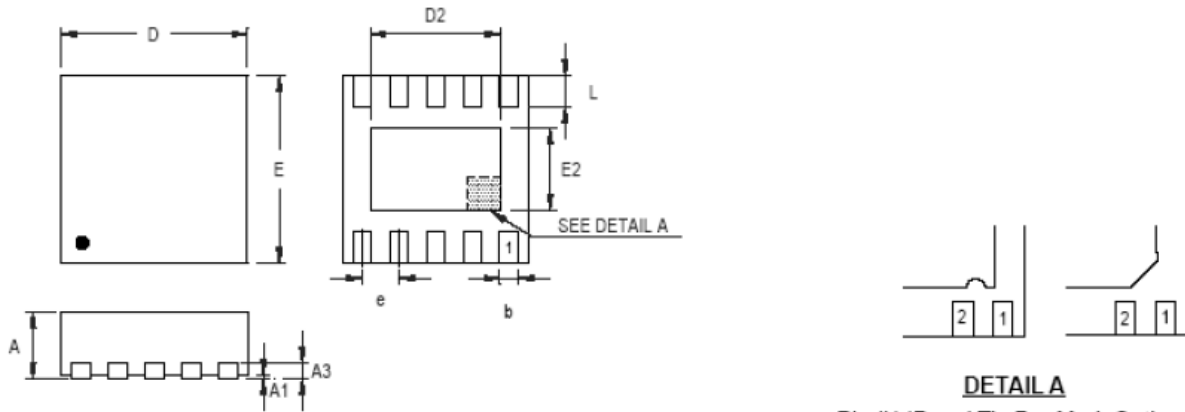

**DETAIL A**

Pin #1 ID and Tie Bar Mark Options

Note : The configuration of the Pin #1 identifier is optional, but must be located within the zone indicated.

Symbol	Dimensions In Millimeters		Dimensions In Inches	
	Min	Max	Min	Max
A	0.700	0.800	0.028	0.031
A1	0.000	0.050	0.000	0.002
A3	0.175	0.250	0.007	0.010
b	0.180	0.300	0.007	0.012
D	2.950	3.050	0.116	0.120
D2	2.300	2.650	0.091	0.104
E	2.950	3.050	0.116	0.120
E2	1.500	1.750	0.059	0.069
e	0.500		0.020	
L	0.350	0.450	0.014	0.018

W-Type 10L DFN 3x3 Package