

**High Performance, Constant Current Switching  
Regulator For 9PCS White LED In Series**

**General Description**

The LP3312 is a 1MHz PWM boost switching regulator designed for constant- current white LED driver applications. The LP3312 can drive a string of up to 9 white LEDs in series, ensuring uniform brightness and eliminating several ballast resistors. The LP3312 implements a constant frequency 1MHz PWM control scheme. The high frequency PWM operation also saves board space by reducing external component sizes. To improve efficiency, the feedback voltage is set to 200 mV, which reduces the power dissipation in the current setting resistor. Highly integration and internal compensation network minimizes as 5 external component counts. Optimized operation frequency can meet the requirement of small LC filters value and low operation current with high efficiency.

**Ordering Information**

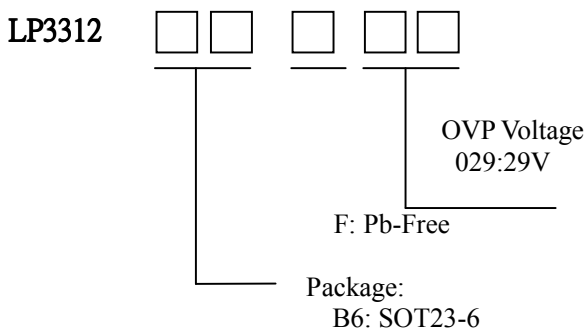

**Pin Configurations**

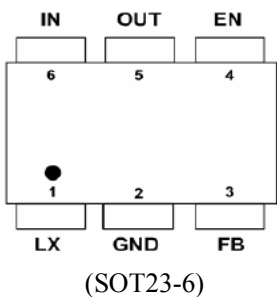

**Features**

- ✧ High Efficiency: 90%
- ✧ 1MHz Fixed-Frequency PWM Operation
- ✧ Maximum Output Voltage up to 29V
- ✧ Operating Range : 2.1V to 6V
- ✧ Shutdown Supply Current: <1uA
- ✧ Available in SOT23-6 Package
- ✧ Built-in 29V Over Voltage Protection
- ✧ Minimize the External Component
- ✧ RoHS Compliant and 100% Lead (Pb)-Free

**Applications**

- ✧ WLED Backlight driver
- ✧ OLED Backlight driver
- ✧ PDA
- ✧ MID/PTV

**Typical Application Circuit**

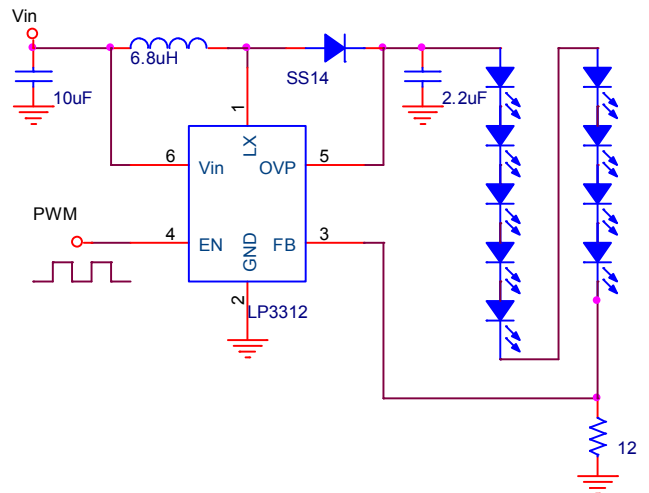

**Marking information**

Please view website.

Functional pin description

SOT-23-6	Pin Name	Pin Function
1	SW	Switch Pin. Connect this Pin to inductor and catch diode. Minimize the track area to reduce EMI.
2	GND	Ground Pin
3	FB	Feedback Reference Voltage Pin. Series connect a resistor between WLED and ground as a current sense. Sense the current feedback voltage to set the current rating.
4	EN	Chip Enable (Active High). Voltage sensing input to trigger the function of over voltage protection. Note that this pin is high impedance. There should be a pull low 100kΩ resistor connected to GND when the control signal is floating.
5	OVP	Over voltage pin.
6	Vin	Supply Input Voltage Pin. Bypass 1uF capacitor to GND to reduce the input noise.

Function Block Diagram

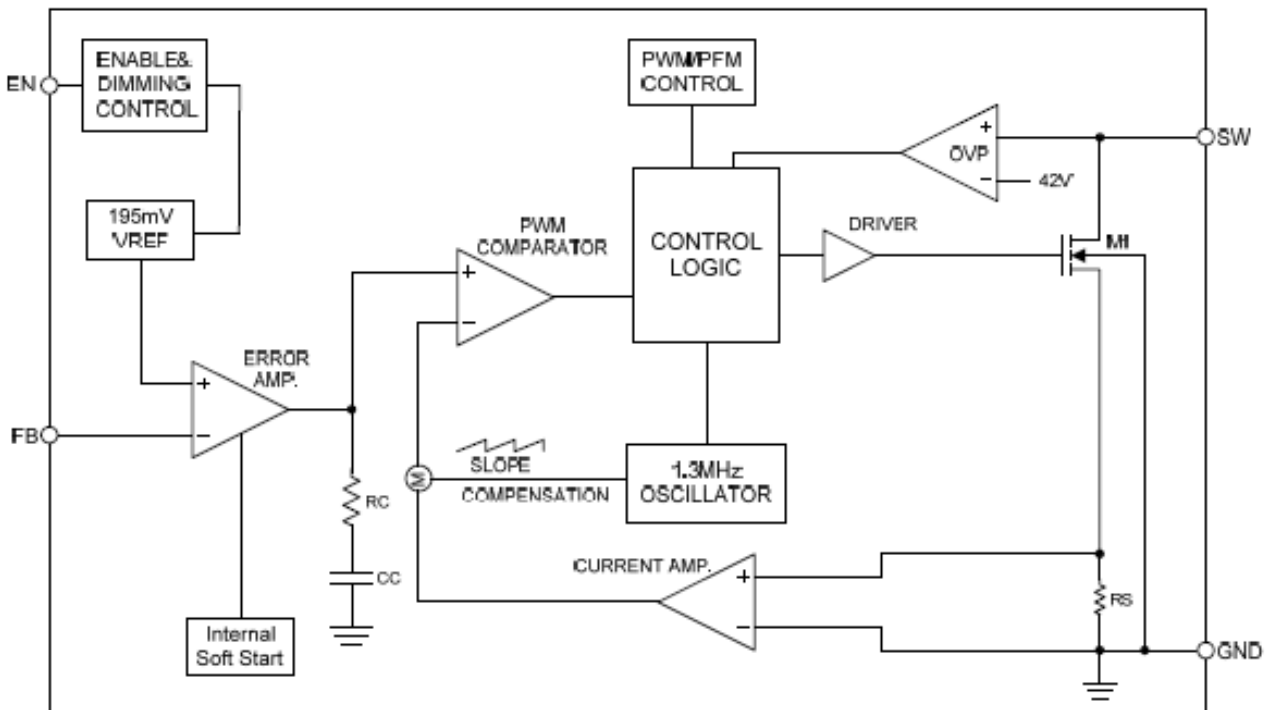

### Absolute Maximum Ratings

Supply Input Voltage-----0.3V to 7V  
 SW Input Voltage -----0.3V to 36V  
 The Other Pins -----0.3V to 7V  
 Power Dissipation, Pd @ TA = 25°C TSOT-23-5/6-----0.455W  
 Lead Temperature (Soldering, 10 sec.) ----- 260°C  
 Operation Temperature Range -----40°C to 80°C  
 Storage Temperature Range -----65°C to 150°C

### Electrical Characteristics

Parameter	Symbol	Test Condition	Min	Typ.	Max	Units
<b>System Supply Input</b>						
Operation voltage Range	VDD		2.1		6	V
Under Voltage Lock Out	VDD		1.6	1.8	2	V
Supply Current	IDD	FB=0.2V, Switch		430	550	uA
Shut Down Current	IDD	VEN < 0.4V		0.1	1	uA
Line Regulation		VIN : 3.0~4.3V		2		%
<b>Oscillator</b>						
Operation Frequency	FOSC		0.8	1	1.2	MHz
Maximum Duty Cycle			93			%
Feedback Voltage			185	200	215	mV
<b>MOSFET</b>						
On Resistance of MOSFET	RDS(ON)			0.3		Ω
SW Current Limit	ILM			2		A
Protection						
OVP Threshold	VOVP			29		V
OVP Sink Current				5		μ A
Shut Down Voltage	VEN				0.6	V
Enable on Voltage	VEN		1.2			V
PWM EN Dimming range			100		100K	Hz

### Typical Operating Characteristics

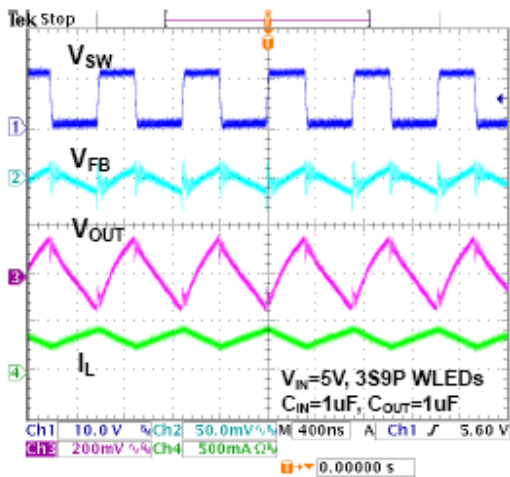

Figure 4. Switch waveforms

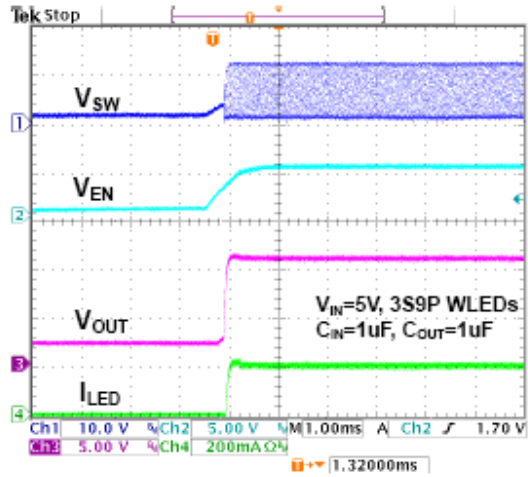

Figure 5. Enable Startup Response Waveforms

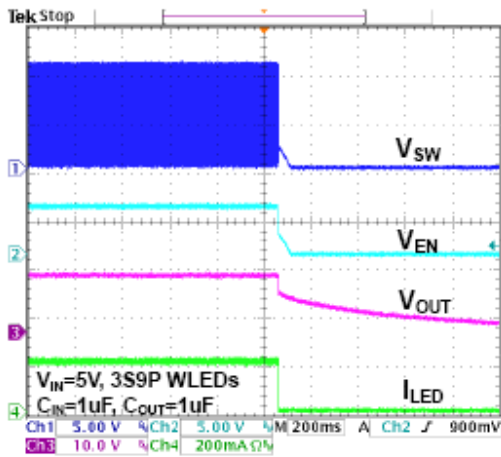

Figure 6. Enable Shutdown Response Waveforms

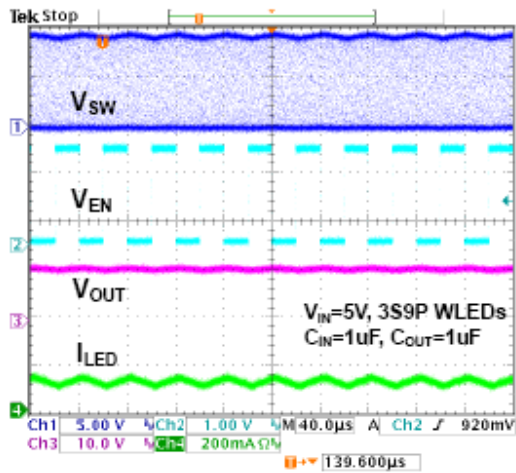

Figure 7. PWM Dimming Response Waveforms at a frequency of 25kHz

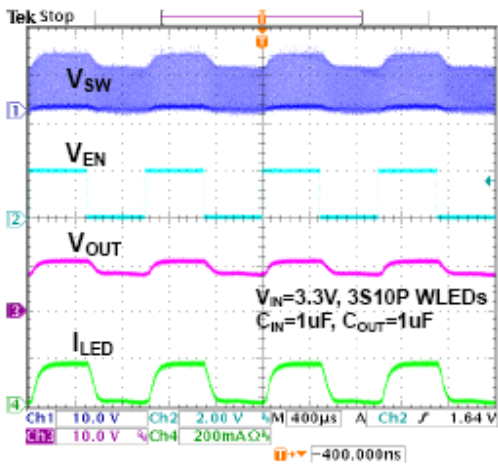

Figure 8. PWM Dimming Response Waveforms at a frequency of 1kHz

## Applications Information

### LED Current Control

The LP3312 regulates the LED current by setting the current sense resistor (R1) connecting to feedback and ground. The internal feedback reference voltage is 20mV. The LED current can be set from following equation easily.

$$I_{LED} = 200\text{mV}/R1$$

In order to have an accurate LED current, precision resistors are preferred (1% is recommended). The table for R1 selection is shown below.

### Inductor Selection

The recommended value of inductor for 2 to 9 WLEDs applications are 6.8 to 22μH. Small size and better efficiency are the major concerns for portable device, such as LP3312 used for mobile phone. The inductor should have low core loss at 1MHz and low DCR for better efficiency. To avoid inductor saturation current rating should be considered.

### Dimming control

#### a. Using a PWM Signal to EN Pin

For controlling the LED brightness, the LP3312 can perform the dimming control by applying a PWM signal to EN pin. The internal soft-start and wide range dimming frequency from 100Hz to 100KHz can insignificantly reduce audio noise when dimming. The average LED current is proportional to the PWM signal duty cycle. The magnitude of the PWM signal should be higher than the maximum enable voltage of EN pin, in order to let the dimming control perform correctly.

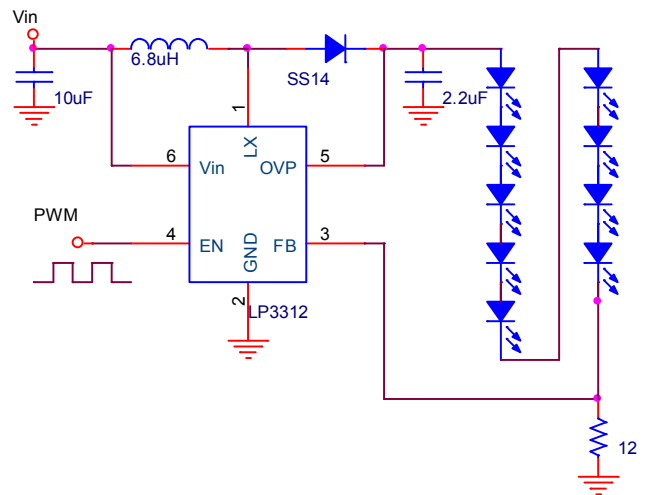

#### b. Using a DC Voltage

Using a variable DC voltage to adjust the brightness is a popular method in some applications. The dimming control using a DC voltage circuit is shown in Figure 4. According to the Superposition Theorem, as the DC voltage increases, the voltage contributed to VFB increases and the voltage drop on R2 decreases, i.e. the LED current decreases. For example, if the VDC range is from 0V to 2.8V, the selection of resistors in Figure 4 sets dimming control of LED current from 20mA to 0mA.

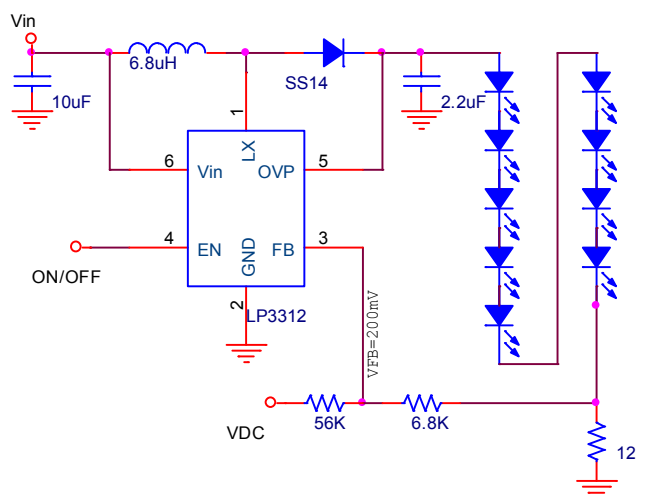

c. Using a Filtered PWM signal

Another common application is using a filtered PWM signal as an adjustable DC voltage for LED dimming control. A filtered PWM signal acts as the DC voltage to regulate the output current. The recommended application circuit is shown in the Figure 6. In this circuit, the output ripple depends on the frequency of PWM signal. For smaller output voltage ripple (<100mV), the recommended frequency of 2.8V PWM signal should be above 2kHz. To fix the frequency of PWM signal and change the duty cycle of PWM signal can get different output current. According to the application circuit of Figure 5, output current is from 20.5mA to 5.5mA by adjusting the PWM duty cycle from 10% to 90%.

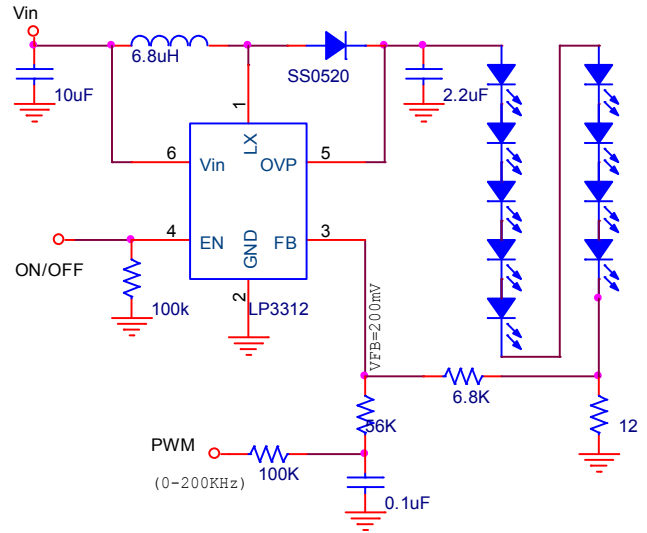

For Larger Panel application Circuit

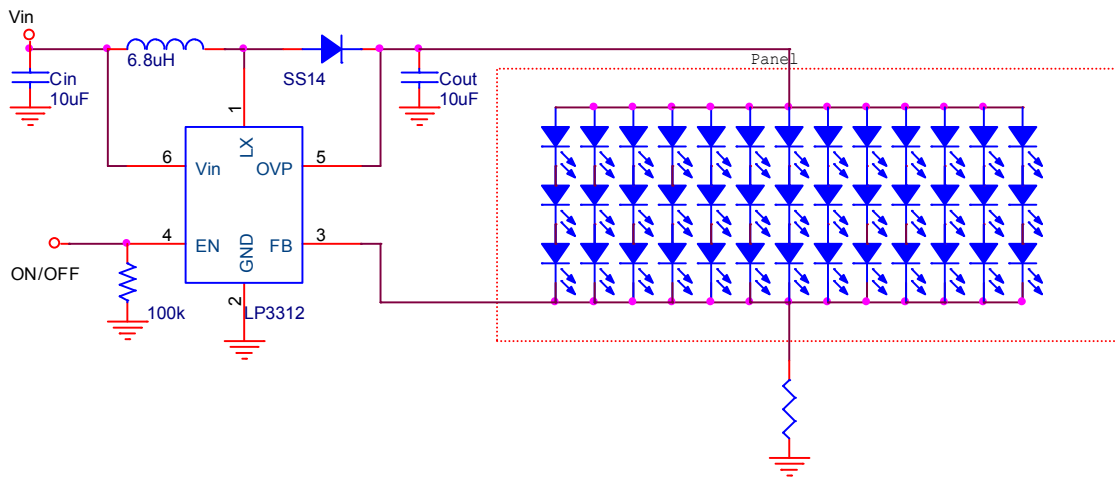

Packing information

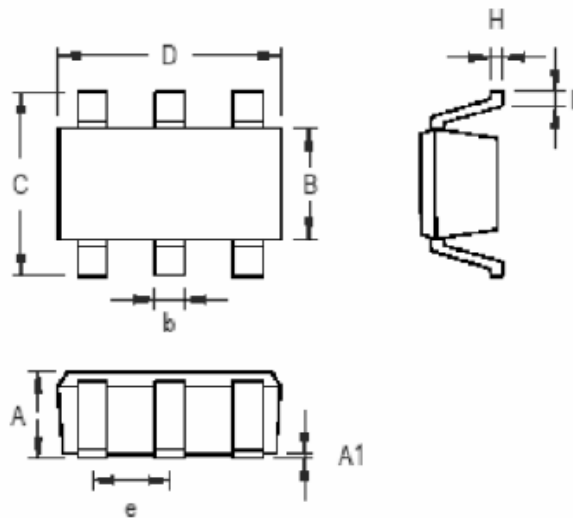

Symbol	Dimensions In Millimeters		Dimensions In Inches	
	Min	Max	Min	Max
A	0.889	1.295	0.031	0.051
A1	0.000	0.152	0.000	0.006
B	1.397	1.803	0.055	0.071
b	0.250	0.560	0.010	0.022
C	2.591	2.997	0.102	0.118
D	2.692	3.099	0.106	0.122
e	0.838	1.041	0.033	0.041
H	0.080	0.254	0.003	0.010
L	0.300	0.610	0.012	0.024

SOT-23-6 Surface Mount Package