

Single-Chip, Li-Ion/Polymer Battery Charge Manager

With Integrated FET and Charge Timer For Handheld Application

General Description

The LP28010 series are highly integrated single cell Li-Ion/Polymer battery charger IC designed for handheld devices. The LP28010 offer integrated power FET and current sensor, reverse blocking protection, high accuracy current and voltage regulation, charge status, and charge termination, in a small package.

The LP28010 charges the battery in three phases conditioning, constant current, and constant voltage. Charge is terminated based on minimum current. An internal charge timer provides a backup safety for charge termination. The LP28010 automatically re-starts the charge if the battery voltage falls below an internal threshold.

Ordering Information

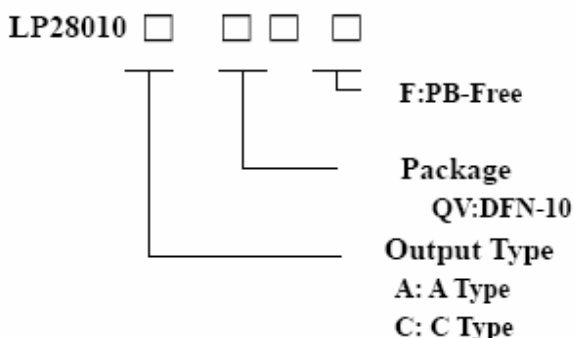

Features

- ◇ Small 3*3mm DFN-10 Package
- ◇ Ideal for Low-Dropout Charger Designs for Single-Cell Li-Ion or Li-Pol Packs in Space Limited Portable Applications
- ◇ Integrated Power FET and Current Sensor for Up to 1-A Charge Applications From AC Adapter
- ◇ Precharge Conditioning With Safety Timer
- ◇ Power Good (AC Adapter Present) Status Output
- ◇ Optional Battery Temperature Monitoring Before and During Charge
- ◇ Automatic Sleep Mode for Low-Power Consumption

Applications

- ◇ Portable Media Players/MP3 players
- ◇ Cellular and Smart mobile phone
- ◇ PDA
- ◇ DSC

Marking Information

Please see website.

Typical Application Circuit

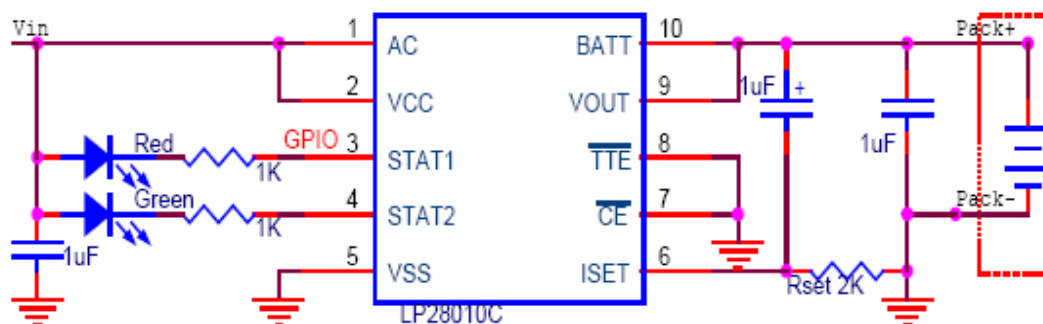

Description

In addition to the standard features, different versions of the Low-power's offer a multitude of additional features. These include temperature sensing input for detecting hot or cold battery packs; Power Good (PG) output indicating the presence of input power; a TTL-level charge enable input (CE) used to disable or enable the charge process; and a TTL-level timer and taper-detect enable (TTE) input used to disable or enable the fast-charge timer and charge termination.

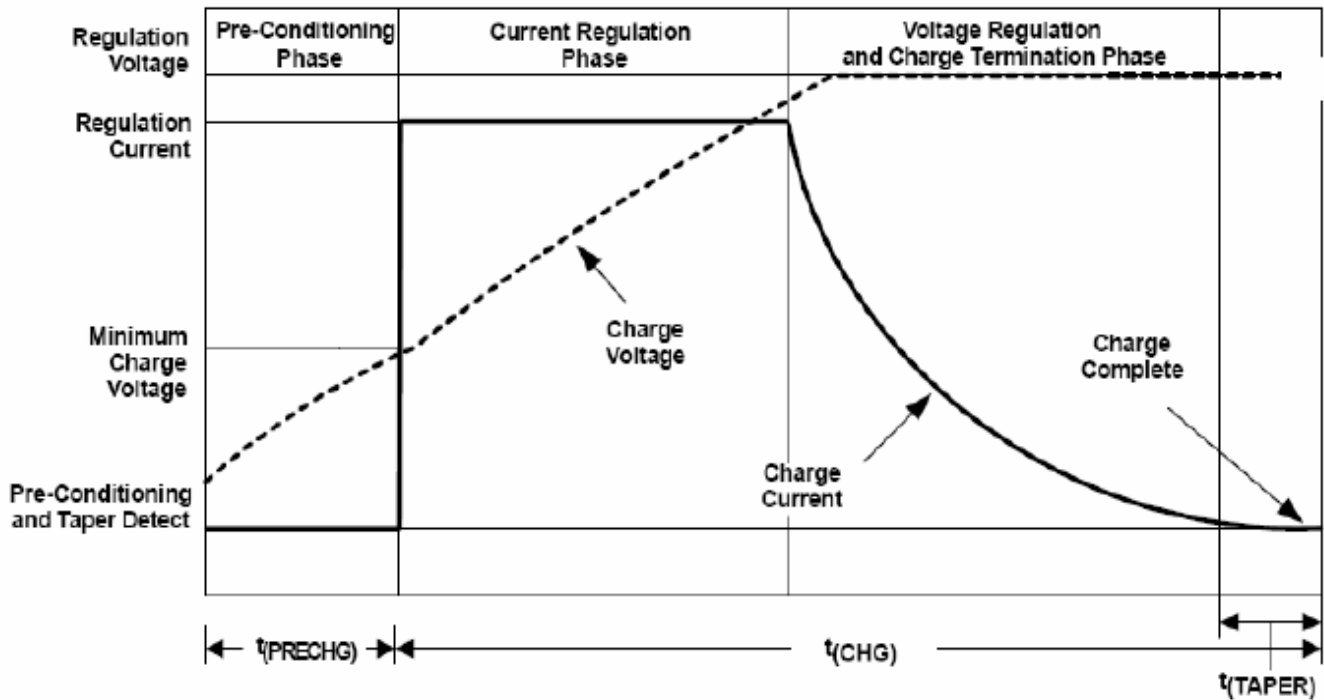
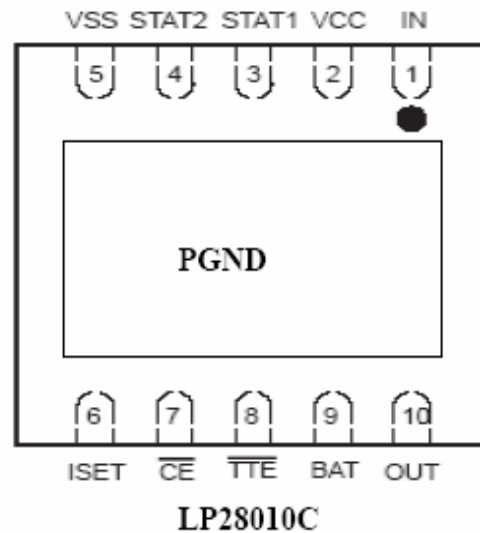
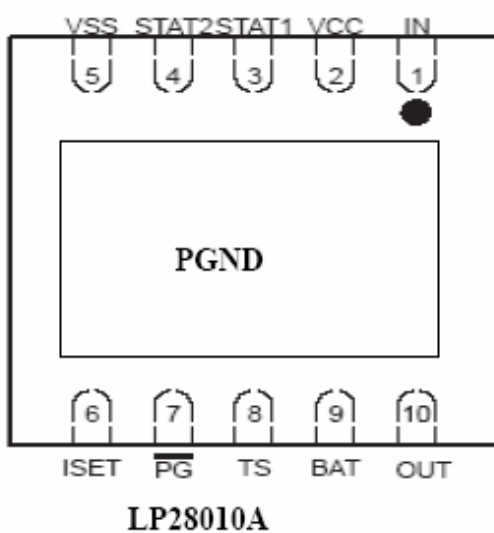

Figure 2. Typical Charging Profile

Functional Pin Description



PIN	LP28010A	LP28010C	DESCRIPTION
AC	1	1	AC charge input voltage
VCC	2	2	USB charge input voltage
STAT1	3	3	Charge status output 1 (open-drain)
STAT2	4	4	Charge status output 2 (open-drain)
VSS	5	5	Ground input
ISET	6	6	Charge current set point for AC input and precharge and taper set point for both AC and USB
PG	7	-	Powergood status output (active low)
TS	8	-	Temperature sense input
CE	-	7	Charge enable input (active low)
TTE	-	8	Timer and termination enable input (active low)
BAT	9	9	Battery voltage sense input
OUT	10	10	Charge Current Output
PGND			Power Gound.

Function Block Diagram

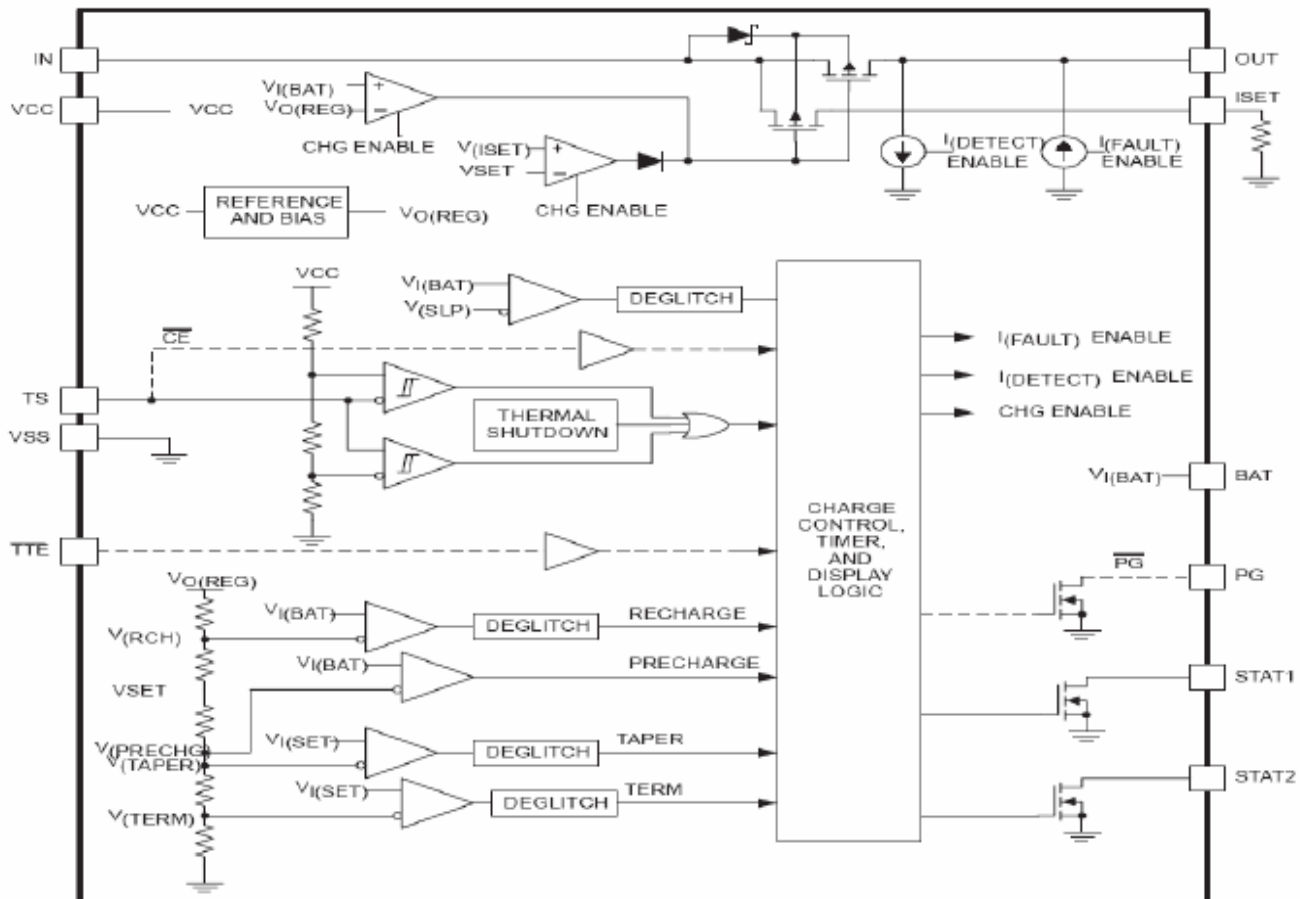

Operation Flow Chart

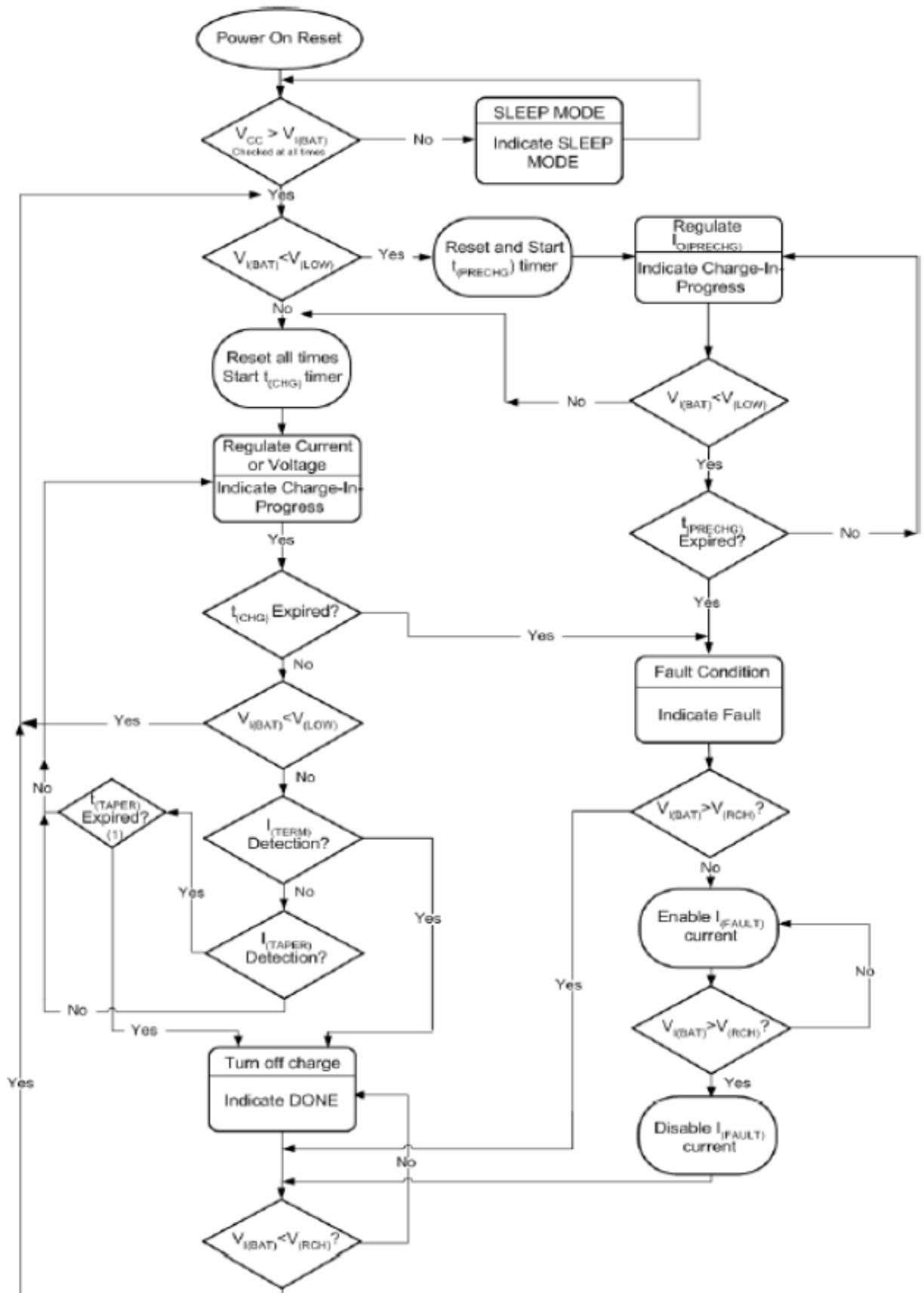

Absolute Maximum Ratings

			LP28010A/C
Input voltage	AC, USB, STAT1, STAT2, TS, PG, CE, TTE, OUT, ISET1, ISET2	-0.3 to 6.0	V
Output sink/source current	STAT1, STAT2, PG	15	mA
Output current	TS	200	μA
Output current	OUT	1.5	A
Operating free-air temperature range, T _A		- 40 to 125	°C
Storage temperature, T _{stg}		- 65 to 150	
Lead temperature 1,6 mm (1/16 inch) from case for 10 seconds		260	

- (1) Stresses beyond those listed under “absolute maximum ratings” may cause permanent damage to the device. These are stress ratings only, and functional operation of the device at these or any other conditions beyond those indicated under “recommended operating conditions” is not implied. Exposure to absolute-maximum-rated conditions for extended periods may affect device reliability.
- (2) All voltages are with respect to VSS.

Dissipation Ratings

Package	θ_{JA}	T _A < 40°C Power Rating	Derating Factor Above T _A = 25°C
DFN-10	48°C/W	1.5W	0.0208 W/°C

RECOMMENDED OPERATING CONDITIONS⁽¹⁾

	MIN	NOM	MAX	UNIT
Supply voltage (from AC input), VCC	4.5		5.5	V
Operating junction temperature range, T _J	-40		125	C

Electrical Characteristics

 (over $0\text{C} \leq T_J \leq 125^\circ\text{C}$ and recommended supply voltage, unless otherwise noted)

PARAMETER	TEST CONDITIONS	MIN	TYP	MAX	UNIT
INPUT CURRENT					
VCC current, ICC(VCC)	VCC > VCC(min)		0.9	1.5	mA
Sleep current, ICC(SLP)	Sum of currents into OUT pin, VCC < V(SLP)		1	5	μA
Standby current, ICC(STBY)	CE = High, $0^\circ\text{C} \leq T_J \leq 85^\circ\text{C}$		50	150	
Input current on OUT pin, IIB(OUT)	Charge DONE, VCC > VCC(MIN)		1	5	
Input current on CE pin, IIB(CE)				1	
Input bias current on TTE pin, IIB(TTE)				1	
VOLTAGE REGULATION $V_O(\text{REG}) + V(\text{DO-MAX}) \leq V_{\text{CC}}$, $I(\text{TERM}) < I_O(\text{OUT}) \leq 1\text{ A}$					
Output voltage, VO(REG)			4.20		V
Voltage regulation accuracy	TA = 25°C	-0.5%		0.5%	
Voltage regulation accuracy		-1.5%		1.5%	
AC dropout voltage (V(AC)-V(OUT)), V(DO)	VO(OUT) = VO(REG), IO(OUT) = 1A VO(REG) + V(DO-MAX)) ≤VCC,		400	500	mV
USB dropout voltage (V(USB) – V(OUT)), USB dro out voltage (V V) V(DO)	VO(OUT) = VO(REG) ISET2 = High VO(REG) + V(DO-MAX)) ≤VCC,		400	500	mV
	VO(OUT) = VO(REG) ISET2 = Low VO(REG) + V(DO-MAX)) ≤VCC,		100	150	
CURRENT REGULATION					
AC output current range, IO(OUT)(1)	VI(OUT) > V(LOWV), VI(AC) –VI(OUT) > V(DO-MAX), VCC ≥ 4.5 V,	50		1000	mA
Output current set voltage, V(SET)	Voltage on ISET1 pin, VCC ≥ 4.5 V, VIN ≥ 4.5 V, VI(OUT) > V(LOWV), VIN – VI(OUT) > V(DO-MAX)	2.41	2.46	2.54	V
Output current set factor, K(SET)Out ut current set factor, K(SET)	50 mA ≤ IO(OUT) ≤ 1 A	294	310	326	
	10 mA ≤ IO(OUT) < 50 mA	284	310	336	
	1 mA ≤ IO(OUT) < 10 mA	246	310	416	
PRECHARGE AND SHORT-CIRCUIT CURRENT REGULATION					
Precharge to fast-charge transition threshold, V(LOW)	Voltage on OUT pin	2.8	3.0	3.2	V
Deglitch time for fast-charge to precharge transition	VCC(MIN) ≥ 4.5 V, tFALL = 100 ns, 10 mV overdrive VI(OUT)	250	375	500	ms

	decreasing below threshold				
Precharge range, IO(PRECHG)(2)	$0\text{ V} < V_I(\text{OUT}) < V(\text{LOWV}), t < t(\text{PRECHG})$	5		100	mA
Precharge set voltage, V(PRECHG)	Voltage on ISET1 pin, VO(REG) = 4.2 V, $0\text{ V} < V_I(\text{OUT}) > V(\text{LOWV}), t < t(\text{PRECHG})$	230	245	260	mV
CHARGE TAPER AND TERMINATION DETECTION					
Charge taper detection range, I(TAPER)(3)	$V_I(\text{OUT}) > V(\text{RCH}), t < t(\text{TAPER})$	5		100	mA
Charge taper detection set voltage, V(TAPER)	Voltage on ISET1 pin, VO(REG) = 4.2 V, $V_I(\text{OUT}) > V(\text{RCH}), t < t(\text{TAPER})$	235	250	265	mV
Charge termination detection set voltage, V(TERM)(4)	Voltage on ISET pin, VO(REG) = 4.2 V, $V_I(\text{OUT}) > V(\text{RCH})$	11	18	25	
Deglitch time for TAPER detection, tTPRDET	$V_{\text{CC}}(\text{MIN}) \geq 4.5\text{ V}, T_{\text{FALL}} = 100\text{ ns}$ charging current increasing or decreasing above and below 10 mV overdrive	250	375	500	ms
Deglitch time for termination detection, tTRMDET	$V_{\text{CC}}(\text{MIN}) \geq 4.5\text{ V}, T_{\text{FALL}} = 100\text{ ns}$ charging current decreasing below 10 mV overdrive	250	375	500	
TEMPERATURE SENSE COMPARATOR					
Low-voltage threshold, V(LTF)		2.49	2.515	2.54	V
High-voltage threshold, V(HTF)		0.495	0.510	0.525	
Current source, I(TS)		102	112	122	μA
Deglitch time for temperature fault, t(DEGL)		250	375	500	ms
BATTERY RECHARGE THRESHOLD					
Recharge threshold, VRCH		VO(REG) -0.15	VO(REG) -0.10	VO(REG) -0.05	V
Deglitch time for recharge detect, t(DEGL)	$V_{\text{CC}}(\text{MIN}) \geq 4.5\text{ V}, T_{\text{FALL}} = 100\text{ ns}$ decreasing below or increasing above threshold,	250	375	500	ms
STAT1, STAT2, and PG OUTPUTS					
Low-level output saturation voltage, VOL	IO = 5 mA			0.25	V
CHARGE ENABLE (CE) AND TIMER AND TERMINATION ENABLE (TTE) INPUTS					
Low-level input voltage, VIL	IIL = 10 μA	0		0.4	V
High-level input voltage, VIH	IIL = 20 μA	1.4			
CE or TTE low-level input current, IIL		-1			μA

CE or TTE high-level input current, I _{IH}				1	
TIMERS					
Precharge time, t(PRECHG)		1,620	1,800	1,930	s
Taper time, t(TAPER)		1,620	1,800	1,930	
Charge time, t(CHG)		16,200	18,000	19,300	
Timer fault recovery current, I(FAULT)			200		μA
SLEEP COMPARATOR					
Sleep-mode entry threshold voltage, V(SLP)	2.3 V ≤ V _{I(OUT)} ≤ V _{O(REG)}	V _{CC} ≤ V _{I(OUT)} + 100 mV			V
Sleep mode exit threshold voltage, V(SLPEXIT)	2.3 V ≤ V _{I(OUT)} ≤ V _{O(REG)}	V _{CC} ≥ V _{I(OUT)} + 190 mV			
Sleep mode deglitch time	AC and USB decreasing below threshold, T _{FALL} = 100 ns, 10 mV overdrive	250	375	500	ms
THERMAL SHUTDOWN THRESHOLDS					
Thermal trip threshold, T(SHTDWN)		165			°C
Thermal hysteresis		30			
UNDERVOLTAGE LOCKOUT					
Undervoltage lockout V(UVLO)	Decreasing V _{CC}	2.4	2.5	2.6	V
Hysteresis		20			mV

$$(3) I_{O(TAPER)} = \left(\frac{K_{(SET)} \times V_{(TAPER)}}{R_{SET}} \right)$$

$$(4) I_{O(TERM)} = \left(\frac{K_{(SET)} \times V_{(TERM)}}{R_{SET}} \right)$$

Applications Information

Temperature Qualification (28010A Only)

The LP28010X continuously monitors battery temperature by measuring the voltage between the TS and VSS pins.

An internal current source provides the bias for most common 10-k Ω negative-temperature coefficient thermistors (NTC) (see Figure 5). The device compares the voltage on the TS pin against the internal $V_{(LTF)}$ and $V_{(HTF)}$ thresholds to determine if charging is allowed. Once a temperature outside the $V_{(LTF)}$ and $V_{(HTF)}$ thresholds is detected the device immediately suspend the charge. The device suspend charge by turning off the power FET and holding the timer value (i.e. timers are NOT reset). Charge is resumed when the temperature returns to the normal range.

However the user may modify these thresholds by adding two external resistors. See Figure 6.

Battery Pre-Conditioning

During a charge cycle if the battery voltage is below the (LOW) threshold, the LP28010X applies a precharge current, $I_{O(PRECHG)}$, to the battery. This feature revives deeply discharged cells. The resistor connected between the ISET1 and VSS, RSET, determines the precharge rate. $V_{(PRECHG)}$ and $K_{(SET)}$ parameters are specified in the specifications table. Note that this applies to both AC and USB charging.

The LP28010 activates a safety timer, $t_{(PRECHG)}$, during the conditioning phase. If $V_{(LOWV)}$ threshold is not reached within the timer period, the LP28010 turns off the charger and enunciates FAULT on the STATx pins. Please refer to the Timer Fault Recovery section for additional details.

$$I_{O(PRECHG)} = \frac{V_{(PRECHG)} \times K_{(SET)}}{R_{SET}} \quad \text{----- (1)}$$

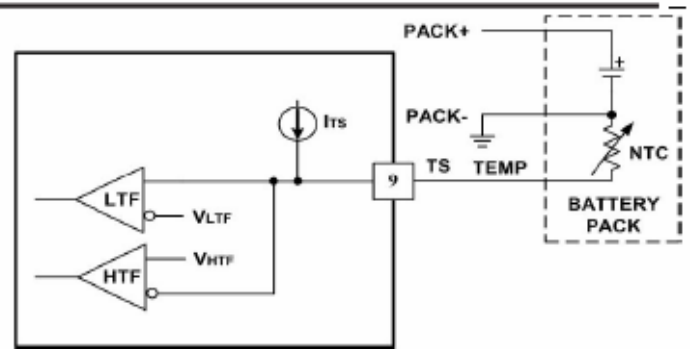

Figure 5. Temperature Sensing Configuration

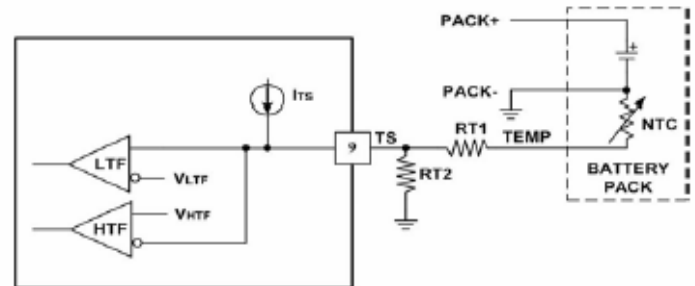

Figure 6. Temperature Sensing Thresholds

Battery Charge Current

The LP28010X offers on-chip current regulation with programmable set point. The resistor connected between the ISET1 and VSS, RSET, determines the AC charge rate. The $V_{(SET)}$ and $K_{(SET)}$ parameters are specified in the specifications table.

$$I_{O(OUT)} = \frac{V_{(SET)} \times K_{(SET)}}{R_{SET}} \quad \text{----- (2)}$$

Battery Voltage Regulation

The voltage regulation feedback is through the OUT pin. This input is tied directly to the positive side of the battery pack. The LP28010X monitors the battery pack voltage between the OUT and VSS pins. When the battery voltage rises to $V_{O(REG)}$ threshold, the voltage regulation phase begins and the charging current begins to taper down.

As a safety backup, the LP28010X also monitors the charge time in the charge mode. If charge is not terminated within this time period, $t_{(CHG)}$, the LP28010 turns off the charger and enunciates FAULT on the STAT pins. Please refer to the Timer Fault Recovery section for additional details.

Charge Taper Detection, Termination and Recharge

The LP28010 monitors the charging current during the voltage regulation phase. Once the taper threshold, (TAPER), is detected the LP28010 initiates the taper timer, (TAPER). Charge is terminated after the timer expires. The resistor connected between the ISET and VSS, RSET, determines the taper detection level. The V(TAPER) and (SET) parameters are specified in the specifications table.

$$I_{(TAPER)} = \frac{V_{(TAPER)} \times K_{(SET)}}{R_{SET}} \quad (3)$$

The LP28010X resets the taper timer in the event that the charge current returns above the taper threshold, (TAPER).

In addition to the taper current detection, the LP28010X terminates charge in the event that the charge current falls below the I(TERM) threshold. This feature allows for quick recognition of a battery removal condition or insertion of a fully charged battery. Note that charge timer and taper timer are bypassed for this feature. The resistor connected between the ISET and VSS, RSET, determines the taper detection level. The V(TERM) and K(SET) parameters are specified in the specifications table.

$$I_{(TERM)} = \frac{V_{(TERM)} \times K_{(SET)}}{R_{SET}} \quad (4)$$

After charge termination, the LP28010X re-starts the charge once the voltage on the OUT pin falls below the (RCH) threshold. This feature keeps the battery at full capacity at all times.

Sleep Mode

The LP28010X enters the low-power sleep mode if both AC is removed from the circuit. This feature prevents draining the battery during the absence of input supply.

Charge Status Outputs

The open-drain STAT1 and STAT2 outputs

indicate various charger operations as shown in the following table. These status pins can be used to drive LEDs or communicate to the host processor. Note that OFF indicates the open-drain transistor is turned off.

CHARGE STATE	STAT1	STAT2
Precharge in progress	ON	ON
Fast charge in progress	ON	OFF
Charge done	OFF	ON
Charge suspend (temperature)	OFF	OFF
Timer fault	OFF	OFF
Sleep mode	OFF	OFF

OFF means the open-drain output transistor on the STAT1 and STAT2 pins is in an off state.

PG Output

The open-drain PG (Power Good) indicates when the AC adapter is present. The output turns ON when a valid voltage is detected. This output is turned off in the sleep mode. The PG pin can be used to drive an LED or communicate to the host processor.

CE Input (Charge Enable)

The CE digital input is used to disable or enable the charge process. A low-level signal on this pin enables the charge and a high-level signal disables the charge and places the device in a low-power mode. A high-to-low transition on this pin also resets all timers and timer fault conditions. Note that this applies to both AC and USB charging.

TTE Input (Timer and Termination Enable)

The TTE digital input is used to disable or enable the fast-charge timer and charge taper detection. A low-level signal on this pin enables the fast-charge timer and taper timer and a high-level signal disables this feature. Note that this applies to both AC and USB charging.

Thermal shutdown and Protection

The LP28010X monitors the junction temperature, T_J, of the die and suspends charging if T_J exceeds

T(SHTDWN). Charging resumes when TJ falls below T(SHTDWN) by approximately 30 °C.

Timer Fault Recovery

As shown in Figure 3, LP28010X provides a recovery method to deal with timer fault conditions.

The following summarizes this method:

Condition #1: Charge voltage above recharge threshold (V(RCH)) and timeout fault occurs

Recovery method: LP28010X waits for the battery voltage to fall below the recharge threshold. This could happen as a result of a load on the battery, self-discharge or battery removal. Once the battery falls below the recharge threshold, the LP28010X clears the fault and starts a new charge cycle. A POR or CE or TTE toggle also clears the fault.

Condition #2: Charge voltage below recharge

threshold (V(RCH)) and timeout fault occurs
Recovery method: Under this scenario, the LP28010X applies the I(FAULT) current. This small current is used to detect a battery removal condition and remains on as long as the battery voltage stays below the recharge threshold. If the battery voltage goes above the recharge threshold, then the LP28010X disables the I(FAULT) current and executes the recovery method described for condition #1. Once the battery falls below the recharge threshold, the LP28010X clears the fault and starts a new charge cycle.

A POR or CE or TTE toggle also clears the fault.

Packaging Information

10-Pin DFN

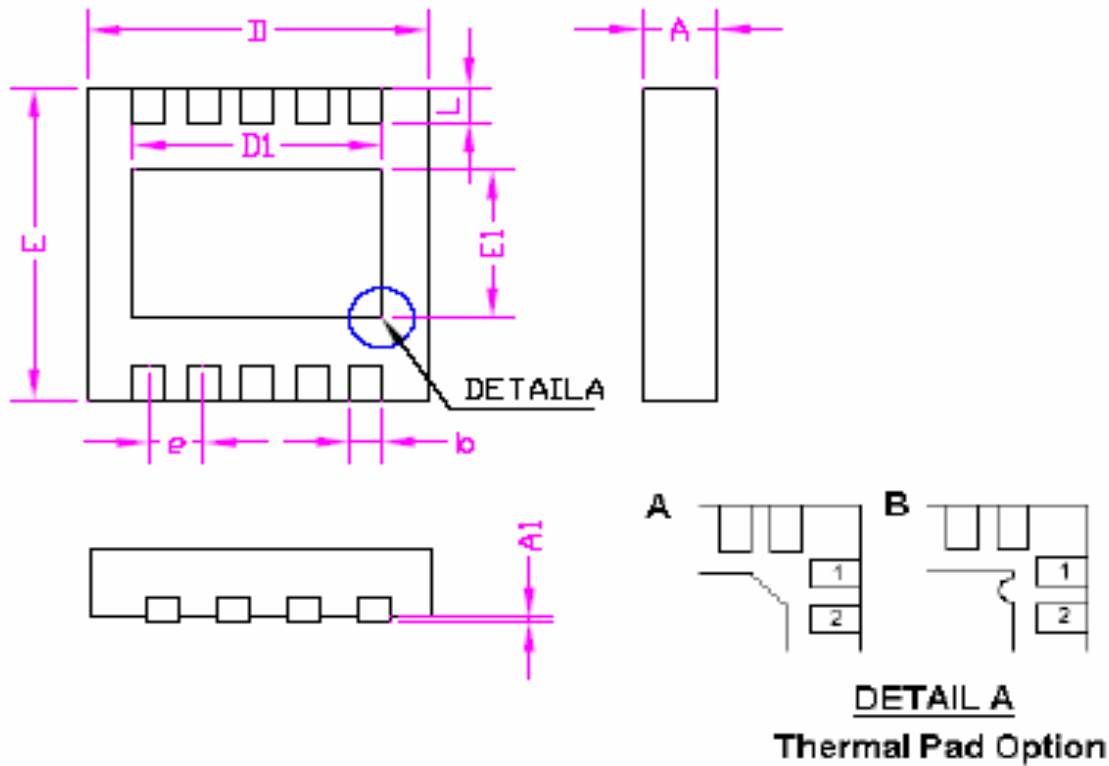

SYMBOLS	MILLIMETERS		INCHES	
	MIN.	MAX.	MIN.	MAX.
A	0.70	0.80	0.028	0.031
A1	0.00	0.05	0.000	0.002
D	2.90	3.10	0.114	0.122
E1	1.70		0.067	
E	2.90	3.10	0.114	0.122
L	0.30	0.50	0.012	0.020
b	0.18	0.30	0.007	0.012
e	0.50		0.020	
D1	2.40		0.094	